

# CHISEL DRESSERS

For form dressing radius and contours on grinding wheels. Our standard chisels are precision lapped diamond having a .005 flat on tip. Standard radius on diamond is .003 - .005. Standard shank length is 3". Other radius available at an additional charge. When ordering add radius at end of tool no. (ex: CH3B6.005R).

TOOL NUMBER	DIAMOND WEIGHT	*A= 40°	*B= 60°	*C= 75°	*D= 90°
CH1 * 6	1/5				
CH2 * 6	1/4				
CH3 * 6	1/3				
CH5 * 6	1/2				
CH7 * 6	3/4				

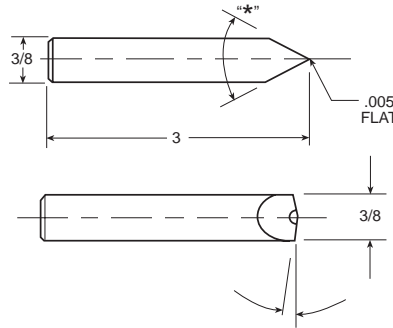

**HOW ORDER**

CH 3 B 6

Tool Type: CH  
Diamond Size: 3  
Included Angle on Diamond: B  
Shank Size: 6

4 = 1/4  
6 = 3/8  
7 = 7/16  
8 = 1/2

A = 40  
B = 60  
C = 75  
D = 90

Relapping available.

# CONE POINTS

For form dressing the diamond in the tool is accurately coned to the specified included angle and radius. These tools are used for precision dressing. Standard radius on diamond is .003-.005. Standard shank length is 2". Other radius available at an additional charge. When ordering add radius at end of tool no. (ex: CH3B6.005R).

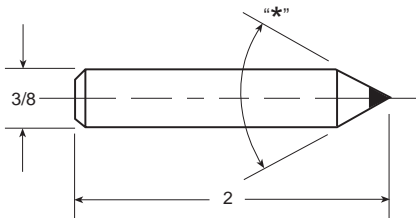

TOOL NUMBER	DIAMOND SIZE	*B=60°	*C=75°	*D=90°
CP1 * 6	1/5			
CP2 * 6	1/4			
CP3 * 6	1/3			
CP5 * 6	1/2			

Resetting and Reconing available.

**HOW TO ORDER**

CP 3 B 6

Tool Type: CP  
Diamond Size: 3  
Included Angle on Diamond: B  
Shank Size: 6

1 = 1/5 CT  
2 = 1/4 CT  
3 = 1/3 CT  
5 = 1/2 CT

B = 60°  
C = 75°  
D = 90°

4 = 1/4  
5 = 5/16  
6 = 3/8  
7 = 7/16  
8 = 1/2

# DIAFORMS

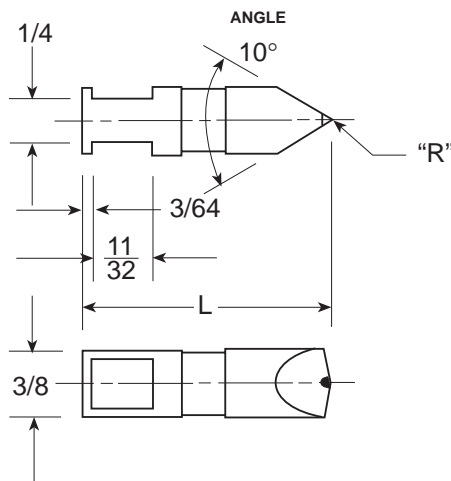

Tool #	Angle	Radius
PWA1*	40°	.005
PWA2*	40°	.010
PWA3*	40°	.020
PWB1*	60°	.005
PWB2*	60°	.010
PWB3*	60°	.020

**HOW TO ORDER**

PW A - 2 H

Tool Type: PW  
Angle: A  
Radius: 2  
Length(\*): H

A = 40°  
B = 60°

1 = .005  
2 = .010  
3 = .020

G = 1 3/8  
H = 1 3/4  
J = 2 1/4

Other angles, radius and length available.