

MOORE PANTOGRAPHS

Tool #	Angle	Radius
MP1A	40	.005
MP2A	40	.010
MP3A	40	.012
MP4A	40	.015
MP5A	40	.020
MP1B	60	.005
MP2B	60	.010
MP3B	60	.012
MP4B	60	.015
MP5B	60	.020

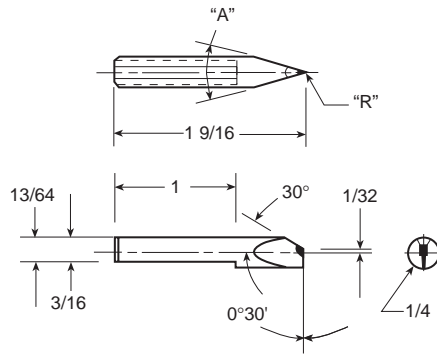

HOW TO ORDER

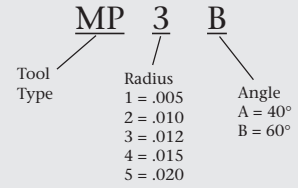

Other angles and radius available.

RATTAIL DRESSERS

To form half circle concave radii

Tool #	To Dress A Min. Radius of
RT31	.032
RT46	.046
RT62	.062
RT93	.093
RT125	.125

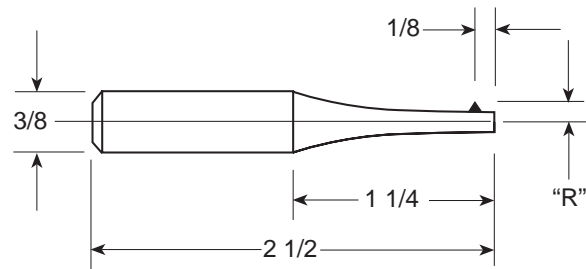

PLUNGE DRESSERS

TOOL #	RADIUS
PL.005	.005
PL.010	.010
PL.015	.015
PL.020	.020
PL.025	.025
PL.030	.030
PL.040	.040
PL.046	.046
PL.050	.050
PL.062	.062

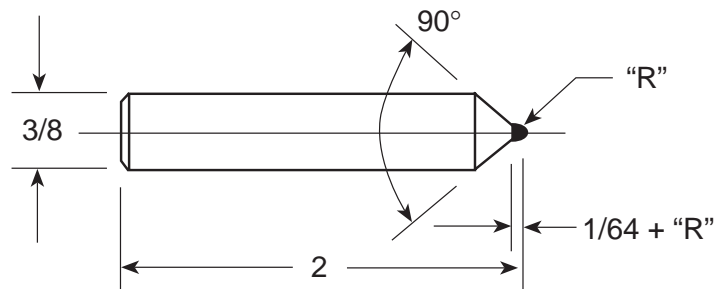

Plunge radius tools are designed to plunge dress a concave radius in the center of a grinding wheel. Frequent turning of the tool will maintain accuracy over a long period of use. For longer life the radius should be rough with a concave dresser.

Additional radius are available.
Please inquire.

Reballing available.