

HOGLUND DRESSERS

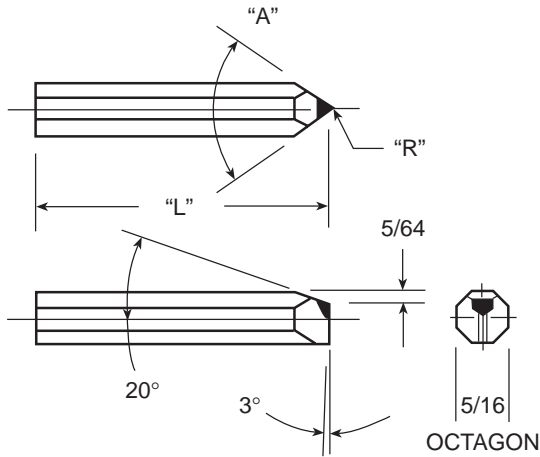

HOW TO ORDER

HG **60** **.010** **A**
 Tool Type Angle Radius Length
 A = 1 1/2
 B = 1 5/8
 C = 1 3/4

JONES & LAMSON

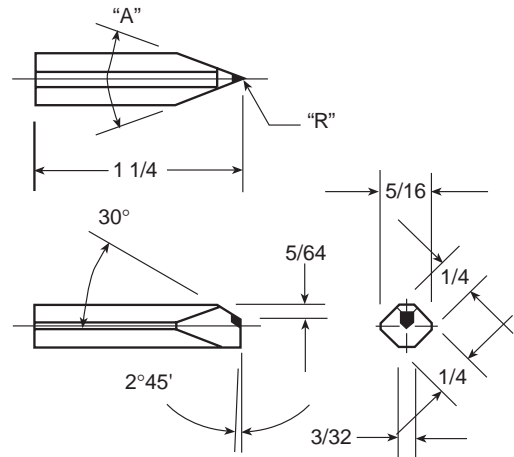

HOW TO ORDER

JL **50** **.007**
 Tool Type Angle Radius

HARDNESS TESTERS

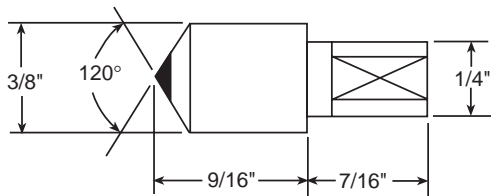

TYPE

Rockwell "C"
 Newage: Versitron
 Newage Versitron (Tapered)

TOOL

STANDARD	PREMIUM
HRCS	HRCP
HNVS	HNVP
HNVTS	HNVTP

Standard and premium grade available.

THREAD GRINDING DRESSERS

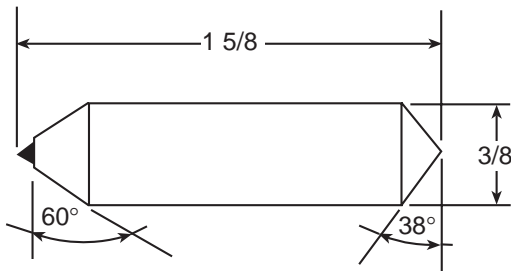

EXCELLO

TOOL

- * EXSD
- * EXTH

* Not Resetttable

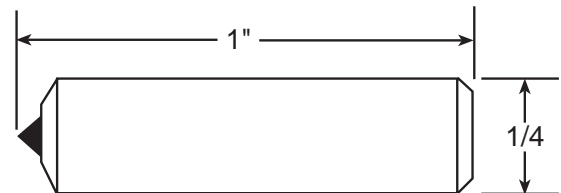

J & L

TOOL

- * JLSD
- * JLTH

* Not Resetttable